

Report  
on

## TRANSPORTATION CONVERGENCE

By Roger Duncan  
Deputy General Manager  
Distributed Energy Services  
and  
Michael J Osborne  
Austin Energy

March 1, 2005



## TRANSPORTATION CONVERGENCE

This report is in response to the Council Resolution 040729-78 requesting that the City Manager investigate the convergence of the electricity and transportation sectors, and its impact on Austin Energy.

### Resolution 040729-78

**WHEREAS**, The City of Austin wishes to become a leader in clean energy development and technology, and to be known as the Clean Energy Capital of the World; and

**WHEREAS**, the transportation sector will ultimately move away from the use of petroleum and will transition to sustainable and non-polluting alternatives; and

**WHEREAS**, there is a great opportunity for electrifying the transportation sector through the use of electric vehicles, plug-in hybrid vehicles, and other non-polluting transportation alternatives; and

**WHEREAS**, there may be substantial economic and environmental benefits for the community from the unification of the stationary electric sector with the transportation sector; and

**WHEREAS**, the transition to a hydrogen economy will create an opportunity for the integration of all of the energy sectors; and

**WHEREAS**, Austin Energy can maximize its benefits to the Citizens of Austin by providing clean transportation fuels; **NOW, THEREFORE**,

**BE IT RESOLVED BY THE CITY COUNCIL OF THE CITY OF AUSTIN:**

That the City Manager is directed to investigate the feasibility of the future integration of the electric and transportation sectors, and its impact on Austin Energy.

## **Executive Summary**

### The Perfect Storm

According to an increasing number of policy makers, industry analysts, and environmental groups, there is a growing awareness of a Perfect Storm of conditions that may change how we drive and what we drive.

This perfect storm of strategic, economic, and environmental conditions compels us to find ways, within a relatively short period of time, to dramatically reduce oil consumption.

Some of these national organizations have even called for a “Set America Free” project.

Important Key Elements in this project include plug-in hybrid electric vehicles and other flexible fuel vehicles. It calls for using electricity as a transportation fuel. Specifically, in the policy recommendations, the Set American Free proponents call for incentives to enable new players, such as utilities, to enter the transportation fuels market.

### Alternatives to Petroleum

There is no “silver bullet” that will easily and cheaply replace petroleum. Rather, there will be many solutions that will combine to first reduce oil consumption, and eventually completely replace it for transportation purposes.

The major alternatives to petroleum are efficiency, alternative fuels, hydrogen, and Electric Fuel. Electricity provides a multi-fuel alternative to petroleum. Electricity can either do the work of running a transportation vehicle, or produce an alternative fuel for the transportation vehicle. It is both a “fuel” and a “fuel maker.”

### Electric Fuel in the Transportation Sector

The idea of using electric fuel to power transportation devices is not new. It is not even uncommon. Many cities in Europe and the rest of the world use bus and light rail systems that are powered by overhead lines.

When Henry Ford finally put a good engine and plentiful gasoline all together in his famous Model T, the head start that Edison gave the electric car industry was lost. And within a decade, the electric car disappeared.

Now, the major reasons behind that disappearance are changing. An electric gallon of gasoline is less expensive than a petroleum-based gallon of gas. Plug-in hybrid cars have no range limitations, and lithium ion batteries can provide 200 to 300 mile ranges for all-electric vehicles. And the price of an electrically fueled vehicle (EFV), although still higher, is only incrementally higher. The savings from the fuel cost differential can make the electric choice a wise economic choice, as well as a solid environmental choice.

## The Gas-Optional Vehicle

We think that a more appropriate designation for a flexible fuel plug-in hybrid should be a “gas-optional vehicle”. You don’t have to put gas in it. You can if you want to, but it would not be necessary.

## The Impacts on Austin and Austin Energy

Electrification of the transportation sector is a very attractive idea for Austin Energy.

One, the transportation sector is roughly equal to the electric sector in Austin. It is therefore a market, which if penetrated, can provide substantial revenue.

Two, electrification of the transportation sector will have substantial environmental benefits. Even in worse case scenarios, using the emissions profiles from our base load coal plants, an electric gallon of gas may be less polluting. Best-case scenarios using wind energy and other renewables are clearly superior to standard gasoline vehicles.

Three, as the rest of the world continues to place growing demand on the resource base, the likelihood of the continuation of cheap oil seems remote at best. Diversifying into electrical fuel will provide Austin residents a hedge against the potential results of high demand and constrained availability.

Four, electrifying the transportation sector can be accomplished without substantial changes in our infrastructure, and it fits well with Austin Energy’s needs and capabilities. Austin Energy’s load at night is 50% of its load in the afternoon. A fleet of electrical transportation appliances charged during this period would therefore not stress our system. More importantly, such a fleet of transportation appliances could store our nighttime wind energy, thus allowing for a larger wind fraction in our overall generation portfolio.

Finally, if Austin Energy and Austin act now, we will be able to reap the benefits of the technological and economic developments that will be realized; and we will profit as a community as such an electric transportation cluster develops.

## Economic Impacts

Using AE’s average residential electric rate of 9 cents per kWh, total annual sales revenue from charging 100,000 EFVs would be 27 million dollars. Although this is a relatively small increase in our overall sales, this level of sales can be met with a minimum of costs.

## Recommendations

### I. Initiate THE GAS OPTIONAL VEHICLE INCENTIVE PROGRAM

A. Promote flexible-fuel plug-in hybrid vehicles as Gas Optional Vehicles (GOVs) through a combination of utility rebates, government fleet purchase commitments, private business fleet commitments, environmental consumerisms and other means.

1. Austin Energy develops a rebate program for a limited number of initial GOVs to government fleets, businesses, and general ratepayers.
2. City of Austin and other local government agencies indicate willingness to place future fleet orders for GOVs.
3. Greater Austin Chamber of Commerce leads effort to enlist private businesses to commit to future GOVs.
4. Austin environmental leaders promote purchase and advance orders of GOVs among Austin environmental community.
5. Austin community supports local, state and federal policies promoting GOVs.
6. Austin provides leadership to 50 largest US cities to adopt a similar incentive.
7. Austin helps organize support for GOVs from key national sectors.

B. Open discussion with state and national organizations regarding the award of emission credits to utilities for reduction of emissions in the transportation sector, based on incentives and the source of fuel for the electrification.

II. Investigate and promote other forms of electric transportation such as Segways, electric bicycles and electric scooters.

III. Investigate the production of alternative fuels, such as hydrogen, as part of a comprehensive approach to powering the transportation sector.

### IV. Develop A COMPREHENSIVE ELECTRIC FUEL INITIATIVE (CEFI)

- A. To promote the use of Electric Fuel in the private sector.
- B. To Promote Electric Fuel in Public Transportation
- C. To promote Electric Transportation Fuel in our Schools, Universities, and other Institutions

## THE CONVERGENCE OF ELECTRICITY AND TRANSPORTATION

Today, there is a common perception that the fuel that runs cars and trucks and the electricity that powers our homes and offices must come from entirely different sources. After all, there is liquid gasoline that goes into our gas tanks, while electricity comes primarily from solid fuels such as coal or uranium or gaseous fuels like natural gas.

The vast majority of fuel used to produce energy in the two sectors is from “fossil fuels” – oil, coal and gas. Yet, the power to run the transportation system and supply energy to our homes and offices can be met both through fossil fuels and “renewable” fuels such as wind, solar, biomass, and geothermal. Both fossil and renewable fuels vary in availability, embedded energy, and difficulty of conversion to useful energy. But the fact is, all fuels can be used in some form to power the electric grid or run the transportation sector.

The concept of the convergence of the electricity and transportation sector is this. In the future, a unified energy sector will power both stationary loads, such as residences, offices, and industries; and it will power mobile loads such as cars, trucks, rail and other means of transportation. This unified energy source will use multiple fuels, and it will be able to generate, store, and move energy between both stationary and mobile sources.

A major step towards this convergence may be the electrification of the transportation sector. And that may be driven by a number of compelling factors.

### **The Perfect Storm**

According to an increasing number of policy makers, industry analysts, and environmental groups, there is a growing “Perfect Storm” of conditions that may change how we drive and what we drive.

This perfect storm of strategic, economic, and environmental conditions compels us to find ways, within a relatively short period of time, to dramatically reduce oil consumption. This is not a matter of just limiting use of foreign oil, since the United States has only 2% of the world’s reserves. Let us look briefly at each of the economic, environmental and strategic drivers.

#### Economic

There has been much talk lately about “Peak Oil”. This is the premise that we are approaching a period in the world oil markets where demand is greater than the availability to supply. Oil production may even “peak” in the very near future. This is a much-debated premise and this report will not try to settle the issue. But it is certainly true that current oil production is straining to meet demand, and demand is rising rapidly.

World oil production is approximately 84 million barrels per day. Demand is about the same, but rising rapidly. China and India are both seeing rapid economic growth, including a large increase in automobiles. The use of oil by China alone has increased to almost 6 million barrels a day. Its demand has almost tripled since 1990.

The United States uses about 20 million barrels a day. Significantly, 97% of our transportation sector is dependent on oil.

Although there is certainly a large amount of “non-traditional” oil, such as the Canadian Tar Sands, and perhaps deep-water reservoirs, the price to produce it will be high.

So while it may or may not be accurate to proclaim “peak oil” is occurring, most people would agree that “cheap oil” – produced by today’s technology from relatively easily reached reserves – is running out.

Gasoline prices are likely to rise in the coming years. It would not be unusual for U.S. gas prices to rise to the levels that Europeans pay today – in the range of 3-4 dollars per gallon. This would certainly have a detrimental impact on our local economy and may be a major influence on the type of vehicles we buy.

## Environmental

### The Clean Air Act

National regulations on emissions that cause Ozone problems, health problems, and “greenhouse gas” emissions are all mandating change in the emissions of both our transportation and electric sectors.

Many major metropolitan areas are designated “non-attainment” areas under the Clean Air Act. All of these areas are looking for ways to clean up “criteria pollutants” – mainly nitrogen oxides and volatile organic compounds – from both their transportation and electric sectors.

Without going into the current debates on global warming and climate change, there certainly seems to be general agreement that regulatory pressures will be coming in future years regarding the control of carbon emissions. Although the United States is not a member, the Kyoto Protocol went into effect internationally February 16<sup>th</sup>. Many large corporations are making plans for compliance with carbon regulations, either because of Kyoto or because they expect some level of carbon regulation is inevitable in the US. Several municipalities, including Austin, have adopted carbon reduction plans.

## Strategic

As mentioned above, since the US holds only about 2% of the world's oil reserves, it now imports 60 % of its oil. This kind of dependence upon foreign oil can be a threat to our national security.

The nation's leading national security citizen organizations have embraced electric fuel in the transportation sector and the plug-in hybrid. The Center for Security Policy (Robert McFarlane), the Center on the Present Danger (James Woolsey), The Foundation for Defense of Democracies, the Hudson Institute, and the National Defense Council Foundation have endorsed a new Set American Free Initiative which calls for tax incentives to automakers, mandates of plug-in hybrids into Federal Fleets, and tax incentives for corporations that switch over their fleets to flexible fuel vehicles.

In their recommendations, they specifically call for new players such as electric utilities to enter the transportation market.

“We're not talking about electric vehicles, but about plug-in hybrid vehicles that can be topped off with electricity for short trips,” James Woolsey, former director of the Central Intelligence Agency, said last month during the unveiling of a report by the 16-member National Commission on Energy Policy. “The potential in terms of national policy, and in terms of global warming, ought to be focused on by anyone” concerned about terrorism or “paying over \$2 a gallon.”

“We think the transportation fuel sector should be diversified by utilizing more electricity as a fuel – plug-in hybrids that can get 100 miles per gallon and allow you to run on electricity alone for 20 to 30 miles, then shift to the combustion engine,” says Gal Luft, director of the Institute for the Analysis of Global Security, an energy-security think tank in Washington.

Early in February, the Natural Resource Defense Council, one of this nation's most respected environmental groups, and the American Council on Renewable Energy, a national association of renewable energy suppliers and manufacturers, announced that they would join these national security groups in Washington in the Set America Free agenda.

This is clearly a significant development and one that shows without much doubt that there truly seems to be a growing consensus in industry and government that fuel diversity in the transportation sector is a good thing.

## **Alternatives to Petroleum**

There is no “silver bullet” that will easily and cheaply replace petroleum. Rather, there will be many solutions that will combine to first reduce oil consumption, and eventually replace it for transportation purposes. Here is a brief summary of the alternatives to petroleum.

### Efficiency

Efficiency is certainly the fastest and cheapest way to reduce oil consumption. But transportation efficiency as measured by gasoline consumption has actually been declining in the US over the last many years.

Increased fuel efficiency standards, if passed, would significantly reduce the demand for oil. But even this is just a reduction in consumption of oil, not a substitute for oil.

In addition to increased fuel standards in the vehicle fleet, a great deal of efficiency can be achieved through telecommunication and telework.

### Alternative Fuels

Alternative fuels come in many forms. The most widely used alternatives today are ethanol, natural gas and propane. Other alternatives include cellulosic ethanol, methane, bio-diesel, and a few others

Some combination of these fuels can be expected to take over a large segment of the transportation sector fuel needs in the future. Some, such as natural gas, may have supply problems in the future. Others still must put in place nation-wide production and distribution centers before they can assume a significant portion of fuel supply. But most can be expected to fuel some portion of the transportation sector as a substitute for oil.

### Hydrogen

Hydrogen deserves some special consideration. Much has been discussed over the last few years about the arrival of the “hydrogen economy”, and particularly the role of the hydrogen fuel-cell car. A hydrogen fuel cell vehicle would convert hydrogen into energy and water vapor, providing a means for clean transportation without dependence on fossil fuels. The best-case scenario uses “green” hydrogen produced from renewable fuels such as wind and solar, or at least emissions-free hydrogen produced from nuclear.

However, the original enthusiasm for hydrogen seems to have waned some recently, as more people begin to realize that the hydrogen fuel cell car is years away from commercialization and that the production and distribution problems in a hydrogen economy are going to be more difficult and expensive to solve than first thought. And, as Joe Romm points out in “The Hype About Hydrogen”, fuel cells will probably first appear economically in the building sector rather than the transportation sector.

Table 4-1

### Summary of Renewable Fuel Options

The most promising renewable transportation fuel alternatives meet four criteria: (1) they can be produced from ample domestic feedstocks; (2) they have low or near-zero carbon emissions during production and use; (3) they work in existing vehicles and with existing infrastructure; and (4) they have the potential to become cost-competitive with petroleum fuels given sufficient time and resources dedicated to technology development.

	Hydrogen	Corn Ethanol	Cellulosic Ethanol	Bio-Diesel	Electricity
<b>Ample, Domestic Resource</b>	<b>Yes</b> Hydrogen can be produced from water through electrolysis or by separating hydrogen from fossil fuels. The U.S. has plentiful coal deposits and abundant water supplies to generate sufficient hydrogen to fuel the domestic transportation system.	<b>No</b> In 2003, roughly 7% of the U.S. corn crop was used to make ethanol. Corn ethanol production will continue to grow, but even use of 100% of the current crop would displace only 25% of current gasoline use on an energy-equivalent basis.	<b>Yes</b> Greater diversity of biomass and waste feed stocks means cellulosic ethanol is likely to be less limited by competing land uses for food and forest products. NCEP analysis suggests potential for substantial production w/o constraining food supply.	<b>Yes</b> Bio-diesel can potentially be made from a wide variety of organic materials, including animal and crop waste, vegetable oils, used grease, etc. Waste quantities generated in the U.S. could support significant production if new technologies for making bio-diesel prove cost-competitive and widely applicable.	<b>Yes</b> The diversity of fuels and technologies used to provide electricity is now much greater than the diversity of fuels used in the transportation sector. Moreover, nearly all electricity used in the U.S. is produced using domestic resources.
<b>Low-Carbon</b>	<b>It depends . . .</b> Three times more carbon intensive per mile than gasoline if produced using electricity from existing power plants. Use of natural gas, renewable, nuclear, or coal power with sequestration would make hydrogen low-carbon, but these technologies will provide greater benefits by directly displacing fossil-based electricity than by in-directly displacing gasoline.	<b>Yes</b> Corn ethanol is roughly 20% lower in greenhouse gas emissions than gasoline. Most emissions result from upstream energy inputs required for the cultivation, harvest, and processing of corn. CO <sub>2</sub> reductions from corn ethanol are modest compared to cellulosic ethanol.	<b>Yes</b> Unlike corn ethanol, has potential to achieve near-zero net carbon emissions. Cultivation of cellulosic feedstocks requires very low energy inputs and, if sustainably managed, the carbon released during fuel combustion is re-absorbed by the growth of new feedstocks.	<b>It Depends . . .</b> Provided it is produced from agricultural crops or wastes, bio-diesel would have very low carbon emissions (similar to cellulosic ethanol).	<b>It Depends . . .</b> Depends on the manner in which the electricity used was generated. The carbon intensity of future electricity production could be greatly reduced by more reliance on renewables and development of next-generation nuclear and fossil technologies with carbon sequestration.
<b>Compatible with Existing Infrastructure</b>	<b>No</b> As a gas, would require a new national distribution infrastructure estimated to cost hundreds of billions of dollars.	<b>It Depends . . .</b> Can be blended with gasoline at varying levels, but cannot now be transported by pipeline and must be moved by barge or truck.	<b>It Depends . . .</b> Infrastructure and vehicle compatibility issues are the same as for corn ethanol.	<b>Yes</b> New synthetic, waste-derived bio-diesels are compatible with existing diesel engines and infrastructure. Some existing vegetable oil bio-diesel can cause problems in older engines at blends greater than 20%.	<b>Yes</b> Assuming plug-in hybrids with short all-electric range, recharging could be done using the existing grid.
<b>Potentially Competitive with Gasoline by 2020</b>	<b>No</b> Substantial technological breakthroughs and dramatic cost reductions are required. National Academy of Sciences estimates 50-year time horizon to full development.	<b>No</b> Technology is mature, but still costs more than twice as much to produce as gasoline (~\$1.40/gal). Current market for corn ethanol is supported by large public subsidies.	<b>Yes</b> Significant progress still needed, but costs have already declined by a factor of three since 1980. NCEP analysis suggests production cost below \$0.80/gal. is attainable.	<b>It Depends . . .</b> Economics of early deployment depend heavily on feedstock costs. In the case of waste-derived fuels, avoided cost of waste disposal can in some instances help to make bio-diesel cost-competitive.	<b>It Depends . . .</b> Battery technology, not electricity itself, is main cost hurdle. Plug-in hybrids are more promising than all-electric vehicles.

Data Sources: National Academy of Sciences, 2004; Romm, 2004 (I); Lynd, Lave, and Greene, 2004; Lynd, Greene, and Sheehan, 2004; International Energy Agency, 2004; Energy Information Administration, 2004; Romm, 2004 (II).

## Electric Fuel

Electricity provides a multi-fuel alternative to petroleum. Electricity can either do the work of running a transportation vehicle, or produce an alternative fuel for the transportation vehicle. This is particularly attractive in relation to hydrogen, where the hydrogen must first be separated from another source, such as natural gas or water, before it is available as a fuel.

There has been much research and emphasis on renewable alternatives to petroleum. A concise summary of these options is contained in the preceding chart from the National Commission on Energy Policy.

Assuming reasonable advances in battery technology, electricity does seem to have several advantages in the competition to reduce oil consumption.

Costs-Calculations done at the Electric Power Research Institute, at Austin Energy, and other utilities show that electricity is already competitive with gasoline in price. This is most dependent on battery costs, and there have been significant advances in battery technology in the past several years. Although electricity prices can be expected to increase in the future, they will probably not increase as rapidly as gasoline. Therefore, the spread between gas and electricity will grow larger.

Infrastructure – One major advantage to fueling the transportation sector through the electric grid is that the infrastructure is already in place. No other alternative to petroleum has such an extensive and reliable fueling infrastructure.

Renewable Energy – Electricity also provides a means for renewable energy, such as wind and solar, to provide fuel for our vehicles. Austin Energy leads the nation in sales of renewable energy among full-service utilities. But without storage, wind and solar are intermittent sources of electricity. The wind that is producing energy for Austin Energy now blows often at night and it is not as strong during hot summer afternoons, the peak power times in Austin. If the evening base load of Austin Energy increases – as would happen with electric or plug-in hybrid vehicles charging – then we would be able to take in more wind power and utilize it without backing down other existing base load facilities. This same situation occurs throughout the nation.

Solar energy could also be stored in automobile batteries, providing solar power for transportation at times when the sun is not shining.

Emissions – Emissions from the electric grid in comparison to petroleum emissions is a complex subject. There are many variables that could determine whether displacing a gasoline fueled car or a diesel truck with electric power from the grid is beneficial to air quality. The principal variables are the type of fuel used for the electricity and the production technology. Clearly, electricity produced from wind, solar and nuclear power produces less air emissions than the combustion of gasoline. Natural

gas and coal may be a mixed bag, with likely reductions in the ozone precursors of nitrogen oxide and volatile organic compounds but probably with an increase in sulfur dioxide and mercury. Again, the exact emission trade-off between electricity and petroleum in the case of coal would depend on the type of coal used and the type of production (conventional, scrubbed, integrated-gasification combined cycle, etc.). Any analysis should be comparing not only current gasoline and power plant emissions, but the future state of the electric grid – with different types of fuels and production – to the future alternatives in gasoline, diesel and alternative fuels.

A full and accurate analysis of emissions is beyond the scope of this report. Furthermore, it is more appropriate for other agencies, such as the Environmental Protection Agency or air-quality and environmental organizations, to conduct their own analysis.

### Barriers

There are two major barriers to wide-scale use of electric or plug-in hybrid vehicles: battery technology and consumer behavior. But, battery technology is advancing rapidly.

Most major manufacturers offer a line of NiMh batteries of all sizes for the broad range of electric tools and appliances that are available at your local hardware store. Honda and Toyota have selected them for their Hybrid lines. One very successful application is in the Toyota Rav 4 all electric vehicle. From 1997 until 2003, 325 all electric RAV4 EVs logged more than 7 ½ million miles.

A project initiated by Southern California Edison in 2000, in partnership with Toyota, showed that 5 RAV 4s had logged 100,000 miles each with little performance degradation.

Lithium Ion batteries offer even more superior characteristics, but they are more expensive than Ni MH batteries. Nissan selected Li Ion for their traction battery of their Altra EV. Energy densities approaching 200 Wh/kg are achievable. And new breakthroughs using nanotechnology are very likely.

In California, AC propulsion has integrated 6800 small cells into a traction battery for Tzero sports car. With the lighter more powerful chemistry of the Li Ion battery, the Tzero has a staggering acceleration from 0 to 60 in 3.3 seconds. It cruises at 70 or 80 and it has a 250 to 300 mile range. Li Ion does have charging and overheating issues that must be managed.

A local electric manufacturer is using Li Ion in their new all-electric prototypes, and there is a local manufacturer of Lithium Ion batteries called Valence Technologies.

Lithium Ion batteries, which are basically laptop batteries, could change the face of electrical transportation. They have four times the energy density of lead acid batteries and they can be charged up to 2000 times.

With Lithium Ion, a broad array of all-electric vehicles with the range of standard gasoline vehicles is possible.

So the Battery barrier may be changing.

The Consumer Behavior barrier may equally be changing. With the advent of the plug-in hybrid, the idea of fueling your car at home becomes more appealing. As long as the consumer knows that his vehicle can be fueled at the usual locations, the convenience of fueling at home becomes more attractive and even a luxury.

Moreover, if the utility company can add the cost of the electric fuel to the customer's bill, the customer will view home fueling in a different light. Inductive fueling will further add to the convenience.

Given that electricity appears to have significant advantages as a fueling alternative, what is the status of electric vehicles? Why have we not seen them on the road? Is there some type of vehicle that would give us the advantages of power from the electric grid without the range and behavior limitations of earlier electric vehicles?

To answer these questions, let's review the history of electric vehicles and particularly the recent emergence of the hybrid car and the potential for plug-in hybrids.

### **Electric Fuel in the Transportation Sector**

The idea of using electric fuel to power transportation devices is not new. It is not even uncommon. Many cities in Europe and the rest of the world use bus and light rail systems that are powered by overhead lines. Many trains are electric. In fact, all trains are really diesel electric.

The first crude electric carriage was invented sometime between 1832 and 1839 by Robert Anderson of Scotland. The head start that Edison gave the electric industry was evident in the transportation industry until a good internal combustion engine was developed with Henry Ford putting it all together in his famous Model T. However, electric vehicles enjoyed success into the 1920's with production peaking in 1912.

The decline of the electric vehicle was brought about by several major developments:

The discovery of Texas crude oil reduced the price of gasoline so that it was affordable to the average consumer.

By the 1920's America had a better system of roads that now connected cities, bringing with it the need for longer-range vehicles.

The invention of the electric starter by Charles Kettering in 1915 eliminated the need for the hand crank.

The initiation of mass production of internal combustion engine vehicles by Henry Ford made these vehicles widely available and affordable in the \$500 to \$1,000 price range. By contrast, the price of the less efficiently produced electric vehicles continued to rise. In 1912, an electric roadster sold for \$1,750, while a gasoline car sold for \$650.

There have been many times in the last 20 years when the return of the electric car was predicted and many were even built. But the battery limitations on the range of the vehicle, combined with higher relative costs than gasoline vehicles, were too great an obstacle to overcome.

The major reasons for the decline of the original electric car have changed. An electric gallon of gasoline is less expensive than a petroleum-based gallon of gas. Plug-in hybrid cars have no range limitations, and lithium ion batteries can provide 200 to 300 mile ranges for all electric vehicles. And the price of an electrically fueled vehicle, although still higher, is only incrementally higher. The savings from the fuel cost differential can make the electric choice a wise economic choice as well as a solid environmental choice.

### Popularity of the Hybrid

Just three years ago, hybrids were a bit of a curiosity. Now they are so popular there is often a wait to get one.

The hybrid car gets its fuel savings from the use of the electric motor in conjunction with a highly efficient internal combustion engine. The gasoline engine runs only when necessary. In the stop and go driving of an urban setting, this feature along with the regenerative braking gives the hybrid its good gas mileage of 45 to 60 MPG.

The two major commercially available hybrids are the Prius from Toyota and the Honda Civic. Both of the vehicles have advanced systems that allow the vehicles to reclaim energy through braking. The Toyota combines both parallel and series drives. That means that the internal combustion engine is used for electrical generation and its power can also be directly applied to the drive train. The Toyota platform has been licensed to other car manufacturers. It can run in all electric mode. Toyota has announced that by 2012 it will have a hybrid version of all its models.

Honda introduced the Civic in 2002. It uses their integrated motor assist hybrid (IMA) drive system. It is a parallel type system with an electric motor generator inserted between the car's combustion engine and its transmission. It is simpler than the Toyota system but it cannot operate in all electric mode.

Many other hybrid models have been announced recently from most major automobile manufacturers. Ford, General Motors, and Daimler Chrysler either have already released or plan to release both sedan and SUV hybrids.

The published miles per gallon for these hybrids is:

Honda Insight:	City 61	Highway 68
Toyota Prius:	City 60	Highway 51
Honda Civic:	City 48	Highway 51
Honda Accord:	City 30	Highway 37
Ford Escape:	City 36	Highway 31

Ford Motor Co. and the U.S. EPA are also working together to develop a unique hybrid, high-efficiency vehicle that uses hydraulic fluid to store and provide energy to power the car. The technology could be used to dramatically improve the fuel economy of sport utility vehicles and light trucks. The hybrid system uses hydraulic pumps and hydraulic storage tanks to store energy in the place of electric motors and batteries used in electric hybrid vehicles. This hydraulic power system could have cost and power advantages over electric hybrid systems, the developers believe.

In the meantime, the plug-in hybrid is taking off.

### The Plug-in Hybrid

The idea of a plug-in hybrid is rather new, even though the concept is rather old. From one perspective, a plug-in hybrid is just an all-electric car with a small on-board generator to keep the batteries charged. In this sense, the engine is a range extender.

An example of this kind of plug-in is found in the Renault Kangeroo Elect'road. It is a small electric van with a range extender. It uses a nickel-cadmium traction battery that provides a 60-mile all-electric range. A 15 kW engine, fed by a two-gallon gasoline tank, drives two alternators to recharge the battery. With the engine running, the range is extended to over 125 miles.

But the plug-in hybrid electric vehicle (PHEVs) that has captured the imagination of policy makers, utility planners, and energy planners is a much more sophisticated device.

The Electric Power Research Research Institute defines a plug-in hybrid as “an electric-drive hybrid vehicle with an all electric operating range. The vehicle utilizes sophisticated electronic controls that permit the use of battery and internal combustion energy to be combined in a very efficient manner, especially in stop and go urban driving.”

A less technical definition from the Institute for the Analysis of Global Security illustrates the attractiveness of this new technology.

“Plug-in hybrid electric vehicles (HEVs) are hybrid cars with an added battery. As the term suggests, plug-in hybrids – which look and perform much like “regular” cars – can be plugged into a 120-volt outlet (for instance each night, or during the workday at a parking garage) and charged. Plug-ins run on the stored energy for much of a typical day’s driving – depending on the size of the battery up to 60 miles per charge, far beyond the commute of an average American and when the charge is used up, automatically keeps running on the fuel in the fuel tank. A person who drives every day a distance shorter than the car’s electric range would never have to dip into the fuel tank.”

Thus in the minds of many, plug-in hybrids have thus become the ideal transportation appliance for unifying the electric sector with the transportation sector.

Much of the plug-in research in this country has occurred at the University of California. Since mid 90s, the Mechanical Engineering department has pretty much lead the way in developing plug-in hybrids. They have found that the plug-in parallel hybrid strategy maximizes energy efficiency and brings air emissions to the lowest levels.

The department has demonstrated its conversions on the Ford Taurus, the Mercury Sable, a Chevy Suburban, and a Ford Explorer. The Suburban had a 60 mile all electric range. The engines can also run on ethanol-based fuels.

The Ford Explorer, which has a 45-mile all-electric range, is estimated to be able to handle more than 50% of the miles driven by the standard SUV driver. Perhaps more importantly, the vehicle is more powerful than a standard Explorer. Its acceleration time for 0 to 60 is 2/3s that of a conventional Ford Explorer. This comes from the 325 HP available from the combined power of the 200 HP electric motor and the engine.

Perhaps the most important work comes from the Electric Power Research Institute (EPRI). EPRI is in the forefront of plug-in hybrid development since the formation of its hybrid electric working group, whose members include the environmental community, automakers, regulatory agencies, power companies, and academic researchers. Their study showed that the plug-in hybrid EV with a 60-mile all electric range has the potential to be the first advanced vehicle to attain the equivalent of 80 miles per gallon (the U.S. Department of Energy goal for midsize sedans) without lightweight materials or extreme aerodynamics

Austin has recently joined with the Electric Power Research Institute in a plug-in hybrid research project in partnership with Daimler Chrysler. This 11 million dollar project will put the first plug-in vehicles on our roads. The EPRI Plug-in Hybrid Vehicle program is now entering an important stage as it broadens beyond the initial 5-vehicle prototype program and reaches out to fleet operators around the globe to increase the development and test program to a 30-vehicle fleet of Sprinter Vans. Austin will receive one of these vans in late 2006.

The van will have a 20 mile all-electric range, and it will offer a 40% reduction in fuel consumption. Perhaps most importantly in the eyes many, it will have **better** acceleration than a stock Sprinter. This van will be a full-sized van capable of proving the plug-in concept on a daily basis on our roads under our conditions. It will provide Austin Energy critical operating and fueling data.

Another utility working on transportation unification appliances is Hydro-Quebec. HQ is developing, through its subsidiaries, a parallel drive train, a battery; and it has even signed an agreement with a French airplane design firm to develop a body for a future plug-in hybrid vehicle.

The concept of a plug-in hybrid seems scalable to many different transportation platforms. We have already mentioned plug-in hybrid vans, sedans and SUVs. There is also a plug-in hybrid electric bucket truck under development. And discussion is underway for the first order of plug-in hybrid school buses.

Some groups are already converting existing hybrids into plug-ins. These groups are changing out the battery and they are hacking into the control system. They have been able to create a plug-in hybrid that drives like a standard hybrid, but because of the greater battery capacity, is capable of extending the gas mileage of the car to almost 100 mpg. It is important to note that these vehicles use the electrical energy purchased from the utility as a fuel extender. This is almost precisely the opposite idea from the all-electric car with a gasoline engine range extender. However, it is an important development. Plug-in hybrids do not need to alter the way a standard hybrid performs as they increase the mileage efficiency of the already efficient hybrid.

Plug-in hybrid vehicles avoid two of the biggest problems with all electric standard electric vehicles. One, they are not limited by range. And two, there is no charge time when the car cannot be driven.

Plug-in hybrids can in fact be more convenient by allowing for convenient home refueling at night.

Sometimes, really good ideas emerge and everyone in the field suddenly realizes that it is an idea that has more than merit; it may be an idea whose time has come.

**Figure 10 Estimated Fuel Economy Potential for Various Hybrid Classifications**

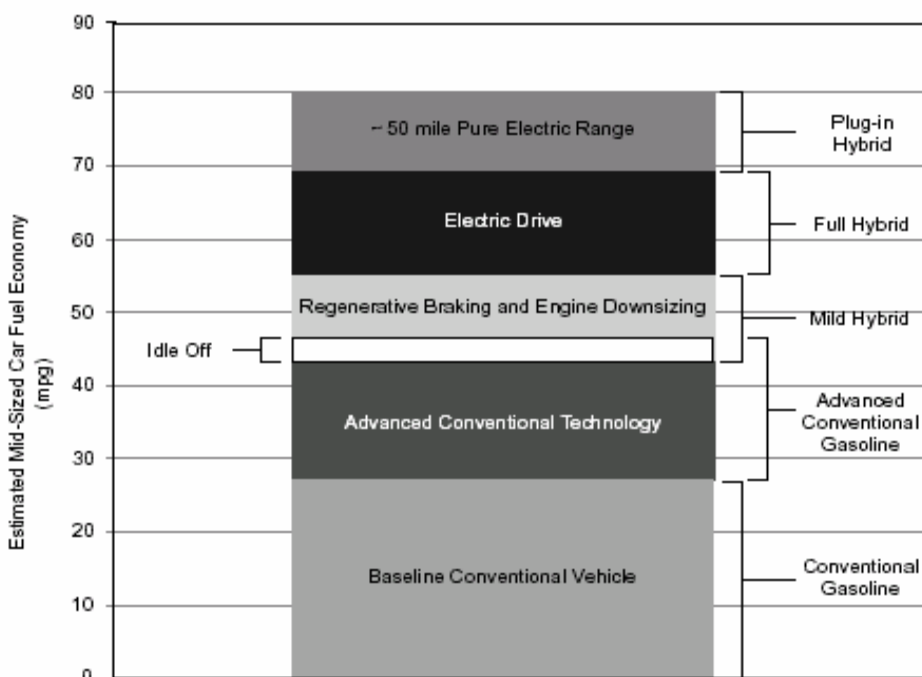

NOTES: Hybrid fuel economy levels assume specific engine and battery/motor sizing in a mid-sized vehicle parallel hybrid driveline configuration, altering that sizing, the driveline configuration, or the vehicle type will affect the fuel economy to some degree. This should only be used as a general guide.

Source: A New Road. UCS

### The Gas-Optional Vehicle

The popular terminology for the current prototypes is “plug-in hybrid”. But we think that a more appropriate designation for a flexible fuel plug-in hybrid should be a “gas-optional vehicle”. You don’t have to put gas in it. You can if you want to, but it would not be necessary. This term for the plug-in hybrid was suggested by a source in southern California.

The unification of the transportation sector with the stationary electric generation sector has significant implications. One, the development of a substantial electric transportation fleet opens up the use of coal and nuclear energy in the transportation sector as well as renewable energy. This affects retailing and fuel markets. Two, air emissions are substantially moved to the source of electrical generation. And the relative mix of emissions may be cleaner than continued use of conventional gasoline engines. These factors affect air quality and health. Three, the use of these fuels short circuits the gasoline tax that is the source of much of our highway funding. This affects government revenues and the quality and number of our roads.

The convergence of these two sectors may be easiest in the areas where local governments own their own utility. Since the local government can control to some

extent the fuel sources of their utility and the composition of their vehicle fleets, there are many opportunities to facilitate this union of clean energy and their transportation fleets.

But we should remember that other alternative fuels could be expected to become competitive to gasoline as well. Certainly the mix of biomass fuels such as ethanol, cellulosic ethanol, bio-diesel and the eventual arrival of hydrogen fuel cells will assume a large share of the transportation sector needs. But there is no reason that an engine burning any of these fuels – or a hydrogen fuel cell – cannot be combined with a plug-in option. So the optimal vehicle is probably a flexible fuel plug-in hybrid. A vehicle that has an internal combustion engine that can run on alternate fuel or a hydrogen fuel cell – combined with an electric motor and option to plug into the electric grid. Such a vehicle could take advantage of competitive prices in both the alternative fuels market and the electricity sector. Such a vehicle would not only be a significant interim step to the hydrogen economy, but an integral piece of any future hydrogen scenario.

### Other Forms of Electrical Transportation

The electrification of the transportation system would certainly be the most significant step towards unification of the electric and transportation sectors. But there are many more aspects of a fully unified system that are worthy to note. First, there may be many forms of electric transportation devices in addition to automobiles.

Perhaps one the most revolutionary transportation developments in the last decade has been the development of the Segway. Here it is in their own words:

“The Segway® Human Transporter (HT) is the first of its kind, a self-balancing personal transportation designed to go anywhere you want to go. It gives you the ability to move faster and carry more, so you can commute, shop, and run errands more efficiently while also adding a little fun to your day. It's compact, yet powerful and rechargeable from any wall outlet.

The Segway HT will change the way you think about travel.

But the Segway HT isn't just about fun transportation. It also makes businesses more productive by allowing workers greater visibility, versatility, mobility and carrying capacity. It does it all by harnessing some of the most advanced, thoroughly tested technology ever created.”

There are tours of Austin now conducted on Segways. Every now and then, they are seen on Congress or around the University.

Although an Austin composed of hundreds of thousands of these transportation appliances is perhaps unlikely, its possibility merits some consideration.

Austin is also home to other retailers of small electric transportation devices. These devices, such as small electric bicycles and small electric scooters could certainly become ubiquitous in a carbon-constrained world.

These devices would also reduce pollution, congestion, and they would increase the use of electric fuel in the transportation sector.

## IMPACTS ON AUSTIN and AUSTIN ENERGY

### **Impact on Austin Energy**

The use of electric fuel in transportation will have significant impacts on Austin Energy. These impacts will include increased revenue, a changed load shape, and with that increased nighttime load, an opportunity to increase wind power.

#### Load

Assuming that vehicles operating in an electric mode travel on average 40 miles per day and that they use 0.25 kWh per mile, average battery charging per vehicle will be 10 kWh per day. If Austin Energy serves 100,000 such vehicles, daily fueling energy would be one million kWh (1000 MWh). Much of this would occur at night.

Assuming that the charging was done uniformly during the eight hours from 10 pm to 6 am, this need would represent 125 MW's of additional load.

#### Revenues

Using AE's average residential electric rate of 9 cents per kWh, total annual sales revenue from charging 100,000 electric fueled vehicles would be 27 million dollars.

$$10 \text{ kWh/day} \times 300 \text{ days/yr} \times 100,000 \text{ EFVs} = 300,000,000 \text{ kWh per year}$$

$$300,000,000 \text{ kWh} \times \$0.09 \text{ per kWh} = \$27,000,000.$$

Additionally, Austin Energy should look for electric revenue opportunities in the mass transit sector. Electric buses or electric light rail could produce additional revenue while helping Austin meet clean air requirements.

This number does not include the substantial economic benefits from the reduced costs of transportation, which although not monetized or internalized, are ultimately realized and paid by the community as a whole.

#### Renewable Energy

As mentioned previously, electrification of the transportation system will allow renewable energy such as wind and solar access to the transportation fuel market. Wind power could be increased into our nighttime load as "GreenChoice" subscribers begin to purchase gas-optional vehicles and plug them in for overnight charging. Even solar could use the auto battery as a storage device. There already is a company making solar carports that could be developed as a direct charging station for the vehicles.

## Productivity

Almost all utilities have unused capacity at night. Austin Energy receives some of its largest amounts of energy from West Texas wind farms during the evening hours. If Austin Energy customers charge their vehicles overnight, the load would match favorably with our wind load profiles.

## Infrastructure

Austin Energy does not anticipate additional infrastructure needs with a modest penetration of the transportation market through plug-in hybrids. If a significant portion of the transportation market switched to electricity, additional power plant facilities would be needed to meet the demand.

Austin Energy may want to install additional infrastructure in the distribution system and charging stations to effectively serve the additional load as well as take advantage of the storage possibilities of a unified system. A future Austin Energy might even be able to use the transportation sector as a way to avoid the construction of some peaking plants.

## Emissions

Since the nighttime base load of Austin Energy is primarily a combination of wind, nuclear and coal, the only pollutants from the displacement of gasoline would be increased emissions from Fayette power plant in accordance with its share of new load. Because of our current and anticipated wind purchases, combined with a base load of nuclear power during the evening hours, it is not anticipated that a moderate increase in Fayette would significantly increase emissions. Of particular note is that Fayette Power Plant is scheduled to install pollution-control “scrubbers” before any new load from plug-ins would happen.

## **Impacts on the City of Austin**

### Air Quality

Austin is currently part of an Early Action Compact, an agreement with the EPA to undertake certain actions, such as vehicle inspections and many more actions to avoid designation as a non-attainment area under the Act.

Any fuel conservation program that causes less fuel to be burned will have a positive impact on air quality. Hybrid-electric vehicles are more fuel-efficient than their counterparts, and plug-in hybrids will be even more efficient.

Removal of ozone precursors from the Austin air, especially in the morning rush traffic hours – when plug-ins and electric vehicles could be expected to be fully charged - would certainly help us meet Clean Air Act requirements. And, with a current nighttime base

load mix of nuclear, coal and wind, we would almost certainly be reducing total emissions from the two sectors combined.

### COA fleet costs

Based on the initial comparisons between a regular gallon of gasoline and an “electric” gallon of gas, fuel costs for our fleets would be reduced. However, there will be additional investments required, and the plug-in feature will add costs.

### Customers

Electric fuel is a better fuel value than gasoline. Using 9 cents/kWh, electric fuel is equivalent to 56 cent per gallon gasoline. Currently, gasoline prices are still hovering near \$2.00. If fuel supplies continue to tighten, the price could certainly be higher.

Any customer – residential or commercial – that used the electric grid to either extend the range of their vehicles in an electric mode or run completely off electricity should expect significant savings over petroleum fuels.

### Economic Development

Austin may see the benefits of additional jobs and economic activity from an electric fuel transportation cluster consisting of battery manufacturers, electric drive component manufacturers, and other electric fuel component manufacturers that recognize the value of Austin, its electric utility, its people, and climate, and thus choose to make Austin their home.

## **In Summation**

There is a sea change occurring. This sea change comes from a growing general consensus among many in Industry and Government that now is the time for Electric Utilities to become participants in the transportation fuel market.

This general consensus comes from an understanding that our present liquid fuel supply chain is very stretched and very delicate. A major loss of production from a major supplier would bring reverberations throughout the liquid fuel markets.

Moreover, there is also a general consensus that the hydrogen fuel cell economy is further away than many have predicted. Because of this, advanced electric fuel appliances and other gas optional vehicles, such as the plug-in hybrid are now on the radar screen.

A growing consensus is seeing the need for **Electric Fuel**, and for the gas-optional plug-in hybrid that makes electric fuel the clean, convenient, and economic **Fuel of Choice**.

## Conclusions

Austin and Austin Energy should support the development of a “Gas-Optional Vehicle”/”plug-in hybrid” along with other appliances and strategies that will allow and facilitate the unification of the electric sector with the transportation sector.

Following is a proposed incentive package for Gas-Optional Vehicles. It is of particular note that this proposal is in agreement with some of the particular recommendations of the “Set America Free” document from the Institute for the Analysis of Global Security.

It calls to “Provide incentives to auto manufacturers to produce and consumers to purchase plug-in hybrid electric vehicles and FFVs (flexible fuel vehicles) across all vehicle models.” It asks governments to “Mandate substantial incorporation of plug-ins and FFVs into federal, state, municipal and covered fleets.” It further calls to “Provide incentives to enable new players, such as utilities, to enter the transportation fuel market”

We feel that the following recommendations will meet the multiple goals of providing incentives for flexible fuel plug-in hybrids and they will begin the process of developing a comprehensive electric fuel policy.

## RECOMMENDATIONS

### I. Initiate THE GAS OPTIONAL VEHICLE INCENTIVE PROGRAM

A. Promote flexible-fuel plug-in hybrid vehicles (Gas Optional Vehicles) through a combination of utility rebates, government fleet purchase commitments, private business fleet commitments, environmental consumerisms and other means.

1. Austin Energy develops a rebate program for a limited number of initial GOVs to government fleets, businesses, and general ratepayers.
2. City of Austin and other local government agencies indicate willingness to place future fleet orders for GOVs.
3. Greater Austin Chamber of Commerce leads effort to enlist private businesses to commit to future GOVs.
4. Austin environmental leaders promote purchase and advance orders of GOVs among Austin environmental community.
5. Austin community supports local, state and federal policies promoting GOVs.

6. Austin provides leadership to largest 50 cities in US to adopt a similar incentive.

7. Austin helps organize support for GOVs from key national sectors.

B. Open discussion with state and national organizations regarding the award of emission credits to utilities for reduction on emissions in the transportation sector, based on incentives and the source of fuel for the electrification.

II. Investigate and promote other forms of electric transportation such as Segways, electric bicycles and electric scooters.

III. Investigate the production of alternative fuels, such as hydrogen, as part of a comprehensive approach to powering the transportation sector.

IV. Develop A COMPREHENSIVE ELECTRIC FUEL INITIATIVE (CEFI)

A. To promote the use of Electric Fuel in the private sector.

B. To Promote Electric Fuel in Public Transportation

C. To promote Electric Transportation Fuel in our Schools, Universities, and other Institutions