



AUSTIN ENERGY
Distribution Interconnection Guide
for Customer Owned Power
Production Facilities
50 kW to <10MW

Approved by:

Carol Bowman



Revision History

Revision	Date	Revised by	Comments
3.0	5/15/2012	Clayton Stice / Sharon Bickford	Minor Revision-update metering and code requirements and include updates to IEEE1547.4, 1547.6
2.0	9/15/2011	Clayton Stice Stanley Consultants TX - 174	Minor revision- Revised Interconnection Package and Forms; included references to Network Installations; consolidated/rearranged divisions and expanded complex metering section due to new ERCOT reporting requirements, expanded codes and references sections
1.0	10/7/2010	Clayton Stice Stanley Consultants TX - 174	Major revision- clarified scope of document for 50 kW to <10MW; Added Appendix A-Interconnection Package and Forms; included references to AE Design Criteria Guide and ESPA; added complex metering to meet ERCOT requirements, expanded definitions, codes and references sections; added hyperlinks to other web references; general rewrite and updates to all sections
Original	9/10/2009	Danny Ee	Original document added to MetricStream.

AUSTIN ENERGY
INTERCONNECTION GUIDE FOR CUSTOMER-OWNED POWER PRODUCTION
FOR FACILITIES 50 kW to <10MW

TABLE OF CONTENTS

	PAGE
A. <u>PURPOSE</u>	04
B. <u>COMPLIANCE WITH APPLICABLE LAWS AND INSTALLATION RULES</u>	
1. Compliance with Laws	06
2. Compliance with Installation Rules.....	06
3. Installation Safety.....	06
4. Applicability.....	06
5. Individual Assessment	06
6. Inspection	06
7. Enforcement.....	07
8. Metering	07
9. Network Installations	07
10. Electric Energy Storage	07
C. <u>GENERAL REQUIREMENTS FOR PARALLEL SYSTEMS</u>	
1. Operating Approval	8
2. Required Customer Data.....	8
3. Interconnection Equipment.....	9
4. Protection Requirements.....	9
5. Maintenance of Protective Equipment.	10
6. Self Protection.....	11
7. Interconnect Studies.....	11
8. Metering	11
9. Identification	12
10. Capital Cost Responsibility	12
11. Operating Safety	12
D. <u>MINIMUM TECHNICAL REQUIREMENTS FOR PARALLEL SYSTEMS</u>	
1. Manual Disconnect	13
2. Voltage and Flicker.....	13
3. Frequency	13
4. Harmonics	14
5. Fault and Loss of Source.	14
6. Power Factor	14

7. Reconnection to AE Service.....	14
8. Coordination and Synchronization.....	14
9. Dedicated Service.....	15
10. Relay Settings.....	15
11. Communication.....	15
12. Additional Requirements for Three-Phase Generators.....	16
13. Additional Requirements for Systems on the AE Network.....	16
14. Additional Requirements for Electric Energy Storage.....	17
15. Other Devices.....	17
E. <u>TECHNICAL EXCEPTIONS</u>	17
F. <u>DEFINITIONS</u>	18
G. <u>CERTIFICATION CODES AND STANDARDS</u>	20

Appendix A. INTERCONNECTION APPLICATION FORM

Distributed Generation Application Approval Process.....	22
1. Application Checklist.....	23
2. DG Application Form.....	24
3. Customer Information.....	25
4. Distributed Generation Application for Solar PV.....	26
5. Distributed Generation Application for Rotating Machines.....	27
6. Facility Information.....	29

A. PURPOSE

Senate Bill 7 (SB 7), Act of May 21, 1999, 76th Legislature, Regular Session, chapter 405, 1999 Texas Session Law Service 2543, 2561 (Vernon) to be codified as an amendment to the Public Utility Regulatory Act (PURA), Texas Utilities Code Annotated §39.101(b)(3) now entitles all Texas electric customers to access on-site distributed generation.

The purpose of this guide is to outline the process for connecting a distributed generation (DG) facility as well as to define the minimum technical and financial requirements for safe integration of customer-owned power production facilities with the AE Distribution System (Note: the typical AE Distribution system is 12.47kV). This information is provided in an effort to maintain safe and reliable service to generating facilities and customers.

This manual is based on the applicable Federal Energy Regulatory Commission (FERC) guidelines (<http://www.ferc.gov/industries/electric/indus-act/gi/small-gen.asp>), Public Utility Commission of Texas (PUCT) rules (if applicable) (<http://www.puc.state.tx.us/agency/ruleslaws/subrules/electric/Electric.aspx>), as well as ERCOT regulations for System Operators and accepted industry practices and standards.

Interconnection Classifications

There are three classifications of interconnections on the AE Distribution system that are defined by the following categories:

1. Small Commercial or Residential Systems less than 50 kW.

Systems less than 50 kW which are not on the Downtown Secondary Network shall refer to the ESPA procedure detailed in the Austin Energy Design Criteria Manual which can be found on the Austin Energy website at:

<http://www.austinenergy.com/about%20us/Rates/index.htm>

These systems are typically handled through the AE Design groups which can be reached at:

[**One-stop shop: \(512\) 974-2632**](tel:(512)974-2632)

2. Medium Systems from 50 kW to <10 MW

Detailed procedures for interconnecting systems from 50 kW to less than 10 MW or Electric Energy Storage systems of any size or systems that are on the AE Secondary Network are covered in this Interconnection guide which is also located on the AE website at:

<http://www.austinenergy.com/About%20Us/Company%20Profile/facilityConnectionReqs.htm>

- a. Any proposed changes by the customer require that an ESPA (Electric Service Planning Application) be filled out and submitted per section 1.4 of the AE Design Criteria Manual which can be found at:

<http://www.austinenergy.com/about%20us/Rates/index.htm>

- b. AE's System Engineering group is the single point of contact for processing DG interconnections 50 kW to <10 MW to AE's distribution system, DG storage systems, as well as any DG system on the Secondary Downtown Network. System Engineering will be responsible for coordinating with Key Accounts, System Operations, Transmission and Distribution Planning, Distribution Design, Network, Regulatory Analysis, and Complex Metering regarding all technical issues associated with interconnecting to the AE distribution system and can be reached at: systemengineeringadm@austinenergy.com
- c. This guide covers most types of Distributed Generation in the AE service areas:
 - i. Inverter based systems- Predominantly Solar PV to date.
 - ii. Synchronous motor systems—Wind generation, standard fossil-fuel based induction motor generators.
 - iii. Other types will be reviewed as encountered.

3. Large Systems of 10 MW or greater

Standards for a facility this large (10MW and up) are not set out in this document and are typically interconnected at the transmission level which is handled by the Manager of Transmission and Distribution Planning. Austin Energy and the customer may interconnect a facility using mutually agreed upon technical standards.

Contact: James.armke@austinenergy.com

- a. Any entity proposing a generation unit greater than ten megawatts (10MW) needs to follow the Generation Interconnection or Change Request Procedure. Details are available on the ERCOT website at: <http://www.ercot.com/gridinfo/generation>
- b. The “Austin Energy Facility Connection Requirements” document may also be referenced and is available on AE's website at: <http://www.austinenergy.com/About%20Us/Company%20Profile/facilityConnectionReqs.pdf>

B. COMPLIANCE WITH APPLICABLE LAWS AND INSTALLATION RULES

1. Compliance with Laws. All customer-owned power production facilities located in the AE service area shall comply with the latest version of the Austin Electrical Utility Service regulations, City of Austin Electrical Code (§25-12-111), Austin Solar Energy Code (§25-12-191), NFPA 70 (National Electrical Code), and NESC (National Electrical Safety Code), as well as the most current version of all other applicable federal, state, or local laws or ordinances as of date of installation. Refer to **Section G** for a listing of additional codes and standards.
2. Compliance with Installation Rules. All customer-owned power production facilities shall also comply with the Installation Rules and Standards for Electric Service established for the AE service area. All equipment rated for use at 600V or below shall be UL listed.
3. Installation Safety. Due to the arc flash hazards present in larger commercial systems, all work on the customer electrical system shall be performed under the direct supervision of a Master Electrician.
4. Applicability for Emergency or Standby Systems. Emergency and/or standby systems as defined in articles 700 and 701 of the NEC not in parallel with the AE electrical distribution system other than brief transition switching periods are not required to follow this Interconnection procedure. However, if the design of the system involves parallel operation with the AE distribution system for periods typically longer than 30 seconds, then the customer is required to follow the procedure outlined in this guide.
5. Individual Assessment. An individual assessment may be required. Because of variations in AE electrical circuits and the multitude of possible generator types and capacities available for customer applications, AE reserves the right to review and approve each request to ensure that suitable protective devices and operating procedures for joint operation will be installed. The customer may be responsible for any or all fees to perform these assessments depending on the size of the proposed DG installation, in addition to costs to perform the interconnection as outlined in section E.6. Fee schedules are available online at: <http://www.austinenergy.com/About%20Us/Rates/feeSchedule.pdf>
6. Inspection. All customer-owned power production facilities shall be inspected for compliance with minimum safety code requirements and installation rules by AE. Isolated systems will also be inspected to ensure that the customer's load and power production equipment are not connected to an electrical circuit in common with the AE system. Inspection approval shall mean only that as of the date of the inspection, the customer's system met minimum code requirements at the time of such inspection and shall not be construed as endorsement, approval or recommendation of a particular system design for the customer's needs nor a representation that the facility continues to comply with such codes following the inspection.

7. Enforcement. AE reserves the right to discontinue electric service to customers who fail or refuse to comply with minimum requirements or applicable law or who, as determined by AE, are operating their power production equipment in a hazardous or unsafe manner. AE may also pursue such other and further rights or remedies as are available to enforce these requirements.
8. Metering. Any entity proposing a generation unit greater than one megawatt (1.0 MW) must follow the Generation Registration Procedure with ERCOT. Details are available on the ERCOT website at: <http://www.ercot.com/services/rq/re/dgresource>
9. Network Installations. Any entity proposing a generation unit in the Austin downtown area must contact AE to verify whether the proposed location is served by the AE Secondary Network, as additional requirements as listed in section D.13 will apply.
10. Electric Energy Storage. Electric energy storage equipment or facilities of any size that are intended to be used in parallel with the AE distribution system are classified as generation assets and are required to follow the interconnection procedure outlined in section D.14.

C. GENERAL REQUIREMENTS FOR DISTRIBUTED GENERATION SYSTEMS OPERATED IN PARALLEL

1. Operating Approval. The customer shall not start up, test or operate electric generating equipment in parallel with the AE electric system without the prior written consent of AE.
 - a. The customer is required to submit an **ESPA** for approval for any interconnection to the AE system.
 - b. The customer is required to obtain an **electrical permit** for construction of any generation facility interfaced to the AE system per Austin Electrical code section §25-12-111
 - c. After the system is installed, and at least 7 business days prior to energizing the system, the customer shall contact AE to arrange for the final inspection to verify that all work has been correctly performed and the system installation complies with all applicable codes and standards.
 - d. AE shall **inspect** the customer's facility and test the performance of any equipment or devices associated with the interconnection or parallel operation of power production equipment. All interconnection-related protective functions and associated batteries shall be tested. The customer shall provide, at their expense, their contractor to assist the AE inspector with this inspection.
 - e. AE shall have the right to disconnect customers who have interconnected without AE authorization.
2. Required Customer Data. Any installation 50 kW and up must be accompanied with a full set of drawings and specifications that have been sealed by a Professional Engineer licensed in the state of Texas. All drawings shall be in electronic files in either pdf or AutoCad 2008 .dwg formats. Files larger than 3 MB should be sent in a zipped or compressed format. Upon request, the customer shall submit to AE all technical data or additional information required to evaluate the proposed customer electrical generating facility, including but not limited to the following:
 - a. Physical layout drawings, including dimensions and interconnection distance
 - b. Schematic drawings up to, and including, the interface to the AE system:
 - i. Electrical main one-line and three-line diagrams, and schematic diagrams
 - ii. System protection details
 - iii. Integration of DG grounding system with AE distribution system per IEEE 1547.
 - iv. Detailed list of equipment: manufacturer's name, model number and rating information as well as operating ranges for frequency, voltage, current, power, power factor, phase rotation, etc.

- v. Manufacturer's test data or certification indicating compliance with national codes concerned with radio noise, harmonic generation, and telephone interference factor
 - vi. Lightning protection and grounding details indicating conformance to NEC article 250
- c. Coordination data such as:
- i. Functional and logic diagrams
 - ii. Control and meter diagrams
 - iii. Conductor sizes and length and technical parameters for circuit impedances
 - iv. Any other data relevant to coordination of the customer system with the AE system
 - v. Systems over 200 kW must also have a written sequence of operation including documented switching procedure(s)
 - vi. Synchronizing methods (if any)
3. Interconnection Equipment. All interconnection equipment on the customer's facility shall be installed and maintained by the customer at their sole expense and in accordance with minimum guidelines established by AE.
- a. AE shall review and approve all customer-selected interconnection equipment and proposed configuration
 - b. Solar PV inverters shall be on the approved list published by the California Energy Commission (CEC) on its website <http://www.gosolarcalifornia.org>
 - c. Inverters in non-Solar PV distributed generation systems must meet requirements of IEEE 1547 and be UL 1741 certified and may not be self commutating.
4. Protection Requirements.
- a. **Three-Phase Facilities rated 50 kW to 1.0 MW must have:**
 - i. Interrupting devices capable of interrupting the maximum available fault current
 - ii. A disconnect device at the service entrance
 - iii. A manual disconnect device for distributed generator in proximity to service entrance
 - iv. An over-voltage trip
 - v. An under-voltage trip
 - vi. An over/under frequency trip
 - vii. An automatic synchronism check relay (if generator is synchronous or self-commutated)
 - viii. Reverse power sensing if the facility is not exporting (unless the generator is less than the minimum load of the customer)
 - ix. If the facility is exporting power, the power direction protective function may be used to block or delay the under frequency trip with the agreement of AE
 - x. Either a ground over-voltage or a ground over-current trip depending on the grounding system. Grounding shall be done in accordance with UL 1741 and NEC Article 250
 - xi. Additional metering to acquire Distributed Generation data as required
 - xii. Refer to simplified diagram in Figure 1

- b. **Three-Phase Facilities rated more than 1.0 MW but less than 10 MW must have:**
- i. Interrupting devices capable of interrupting the maximum available fault current. If the facility is exporting to the AE system, it shall have a redundant circuit breaker unless a listed device suitable for the rated application is used
 - ii. An interconnection disconnect device
 - iii. A generator disconnect device in proximity to service entrance
 - iv. Utility grade relays approved by AE and compatible with AE relay communication. The relay shall provide the following functions at a minimum:
 - 1) An over-voltage trip with sensing/readout by phase
 - 2) An under-voltage trip with sensing/readout by phase
 - 3) An over/under frequency trip with sensing/readout by phase
 - 4) An automatic synchronism check relay (for facilities with stand-alone capability)
 - 5) Reverse power sensing by phase if the facility is not exporting (unless the facility is less than the minimum load of the customer)
 - 6) Telemetry/transfer trip (may be required as part of a transfer tripping or blocking protective scheme) to be done in accordance with IEEE 1547
 - 7) Either a ground over-voltage or a ground over-current trip depending on the grounding system. Grounding shall be done in accordance with UL 1741 and NEC Article 250
 - 8) If the facility is exporting power, the power direction protective function may be used to block or delay the under frequency trip with the agreement of AE
 - 9) On-board data acquisition and event log to record actual readings for all events
 - v. An automatic voltage regulator (AVR) (for facilities with stand-alone capability)
 - vi. Advanced power factor revenue metering as required by ERCOT and AE to provide information to ERCOT and data to AE
 - vii. Energy Management System (EMS) or Supervisory Control and Data Acquisition (SCADA) circuit between the generator's site and AE's control center for monitoring

5. **Maintenance of Protective Equipment.** The customer shall provide a maintenance schedule and perform maintenance of protective equipment at their sole expense at least every two (2) years, or as mandated by current standards, equipment manufacturer recommendations, or as required by AE to provide a safe, reliable system while operating in parallel with the AE system. Circuit breakers must be trip-tested by the customer at least once each year.
- a. A periodic test report log shall be maintained. Testing shall include but is not limited to, for example, the tripping of the circuit breakers by the protective relays. The customer shall provide appropriate access to all facilities for the purpose of such inspections. AE reserves the right to periodically re-inspect the system with prior notification to the customer.
 - b. **Maintenance Records.** Maintenance records for parallel systems must be provided to AE upon request.

6. Self Protection. The minimum protection requirements are designed and intended to protect the Austin Energy electrical distribution system only. The customer shall provide at their sole expense, all devices necessary to protect the customer's electrical generating system by conditions that may occur on the AE system resulting in interruptions and restorations of electrical service. The equipment so installed must protect the customer's electric generating system from overvoltage, undervoltage, overload, short circuits including ground fault conditions, open circuits, phase imbalance and reversal, over and under frequency conditions and other injurious electrical conditions that may arise during the operation of the AE system.
7. Interconnect studies. Detailed interconnect studies may be required if the generation is connected to AE's distribution system and AE determines it to be necessary for safety and reliability purposes.
 - a. Facilities rated from 50 kW to 1.0 MW:
 - i. Interconnect study typically not required for equipment pre-certified to UL 1741.
 - ii. If an interconnect study is desired, AE to bear all costs for studies performed.
 - b. Facilities rated from >1.0 MW but less than 10 MW:
 - i. Interconnect study typically required at customer's expense.
 - ii. Austin Energy shall determine the cost and timeline for performing a detailed interconnect study.
8. Metering.
 - a. Installations from 50kW to 1.0 MW:
 - i. AE will provide in accordance with approved AE Electric Rate Schedules and section 1.9 of the AE Design Criteria manual (<http://www.austinenenergy.com/About%20Us/Company%20Profile/AEDesignCriteria.htm>) at the time of application, the additional metering equipment necessary to measure capacity and energy delivered to, or received from, the customer's distributed generation facility.
 - ii. Refer to **Figure 1** for typical metering installation.
 1. Facilities with <200amp current would typically use a self-contained meter
 2. Facilities with >200amps current would typically use a transformer rated meter.
 3. Final determination of meter type and configuration shall be made by the AE metering group.
 - iii. **Contact AE Complex Metering: (512) 505-7045**
 - b. Installations >1.0 MW to <10MW:
 - i. The distributed generation facility owner will need to register the resource with ERCOT. Refer to ERCOT website for more information: <http://www.ercot.com/services/rq/re/dgresource>
 - ii. AE shall provide at the customer's expense the necessary additional advanced power factor revenue metering equipment for data acquisition and evaluation of the interconnection to the AE system.
 - iii. **Contact AE Complex Metering: (512) 505-7045**

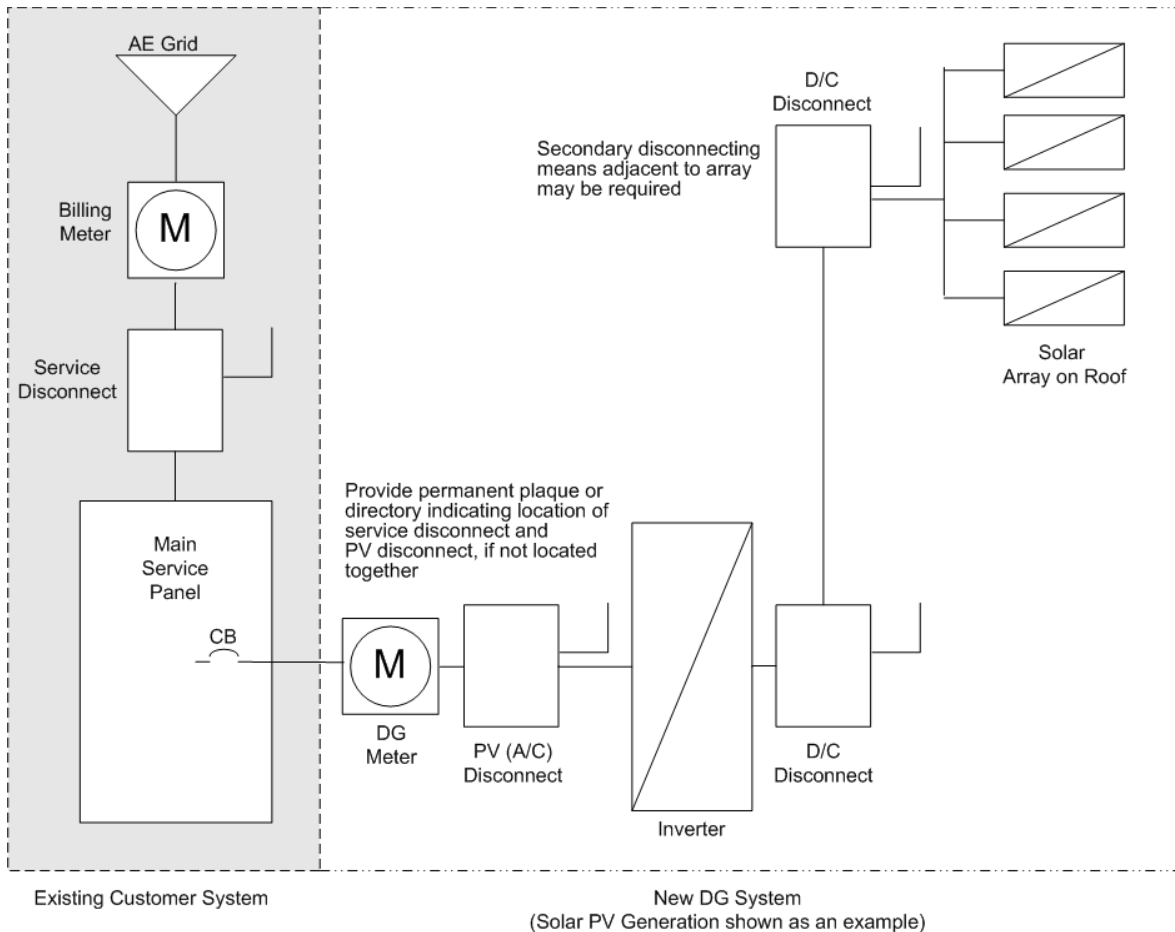

Figure 1. Simplified Diagram for small (<1 MW) Distributed Generation

9. Identification. A directory/plaque of all DG sources including contact information shall be provided as per NEC articles 690 and/or 705.
10. Capital Cost Responsibility. The customer is required to bear all initial and subsequent costs associated with the change-out, upgrading or addition of protective devices, transformers, poles, line, services, meters, switches, and associated equipment and devices beyond that which would be required to provide normal service to the customer if no generation was involved. The customer shall be invoiced for all material and labor that are required in excess of those covered by other applicable installation charges or fees (see appropriate schedules). Upon written request, AE shall supply the customer a cost estimate prior to any work being done.
11. Operating Safety. Adequate protection and documented operational procedures must be jointly developed and followed by the customer and AE for each customer power production facility operating in parallel with the AE system. These operating procedures must be approved by both the customer and AE. The customer shall be required to furnish, install, operate and maintain in good order and repair and be solely responsible for, without cost to AE, all facilities

required for the safe operation of a customer generation system in parallel with the AE system.

D. MINIMUM TECHNICAL REQUIREMENTS FOR PARALLEL SYSTEM

1. **Manual Disconnect.** A manual load break disconnect switch shall be provided at the customer's distributed generation service point to provide a separation point between the customer's electrical generation system and the AE electric utility system. **In addition, solar PV system disconnects shall also comply with the City of Austin Solar Energy Code. AE will coordinate and approve the location, and type of the disconnect switch(es). The disconnect switch(es) shall be mounted separately from the metering equipment, readily accessible to AE personnel at all times, and capable of being locked in the open position with an AE padlock.** AE reserves the right to open the disconnect switch isolating the customer's electrical generating system (which may or may not include the customer's load) from the AE system for the following reasons:
 - a. To facilitate maintenance or repair of the AE electric system or of the distributed generation system
 - b. During AE electric system emergency conditions
 - c. When the customer's electrical generating system is determined to be operating in a hazardous or unsafe manner or unduly affecting AE's voltage waveform
 - d. When the customer's electrical generating system is determined to be adversely affecting other electric consumers on the AE system
 - e. Failure of the customer to comply with applicable codes, regulations and standards in effect at that time
 - f. Failure to abide by any contractual arrangement or operating agreement with AE
2. **Voltage and Flicker.** AE shall endeavor to maintain the voltages on the AE system but shall not be responsible for factors or circumstances beyond its control. If the customer's electrical generation equipment has voltage control capability, it shall be operated in the manual mode with power factor control consistent with the power factor requirement set out below. The customer owned equipment will not cause AE system voltage to go outside of the limits set by ANSI C84.1. The customer shall provide an automatic method of disconnecting its generation equipment from the AE system per IEEE 1547 Section 4-Interconnection Technical Specifications and Requirements. In addition, the customer's electrical generation shall not cause excessive voltage flicker on the AE system. In accordance with IEEE 519, the flicker shall not exceed 3.0% voltage dip, measured at the point of common coupling. If high or low voltage complaints or flicker complaints result from the operation of the customer's electrical generation, the customer's generating system shall be disconnected until the problem is resolved.
3. **Frequency.** AE will endeavor to maintain a 60-hertz nominal frequency on the AE system. If the customer's electrical generation equipment has speed or frequency control, it shall be operated in the manual droop mode. In accordance with the frequency limits of IEEE 1547 Section 4-Interconnection Technical Specifications and requirements, the customer shall provide an automatic method of disconnecting its generation equipment from the AE system in the clearing times specified.

- a. The automatic disconnecting device may be of the manual or automatic reclose type and shall not be capable of reclosing until the AE System voltage and frequency return to normal range and the system is stabilized for the duration specified in (7) below.
4. Harmonics. In accordance with IEEE 519 and 1547 (and UL 1741 for inverter based systems), the output sine wave distortion from the customer's electrical generation system shall not cause voltage harmonic content or total harmonic distortion (THD) in excess of 5% of the fundamental 60-hertz frequency nor, 4.0% of the fundamental frequency for any individual harmonic when measured at the point of common coupling with the AE system.
5. Fault and Loss of Source. In accordance with IEEE 1547, in the event of a fault on the customer's system or a fault or loss of source on the AE system, the customer shall provide an automatic method of disconnecting its generation equipment from the AE system within 10 cycles should the voltage on one or more phases fall below 50.0% of nominal voltage on the AE system serving the customer premises at the point of common coupling.
 - a. The automatic disconnecting device may be of the manual or automatic reclose type and shall not be capable of reclosing until the AE System voltage and frequency return to normal range and the system is stabilized for the duration specified in (7) below
 - b. The type and size of the device shall be specified by AE depending upon the installation. Adequate test data or technical proof that the device meets the above criteria must be supplied by the customer to AE.
 - c. To enhance reliability and safety and with AE's approval, the customer may employ a modified relay scheme with delayed tripping or blocking using communications equipment between the customer and AE.
 - d. This disconnect timing also ensures that the generator is disconnected from the AE System prior to automatic re-close of breakers.
6. Power Factor. The customer's electrical generation system shall be designed, operated and controlled at all times to provide reactive power requirements at the point of interconnection from 0.95 lagging to 0.95 leading power factor. Induction generators shall have static capacitors that provide at least 95% of the magnetizing current requirements of the induction generator field. AE may, in the interest of safety, authorize the omission of capacitors. However, where capacitors are used for power factor correction, additional protective devices may be required to guard against self-excitation of the customer's generator field.
7. Reconnection to AE Service. After any disturbance resulting in a service interruption or breaker actuation, no Distributed Generation source may reconnect until the AE System voltage and frequency return to normal range and the system is stabilized for a period up to 5 minutes, or as required by AE.

8. Coordination and Synchronization. The customer shall be responsible for coordination and synchronization of the customer's electrical generating system with all aspects of AE's electrical system, and the customer assumes all responsibility for damage or loss that may occur from improper coordination and synchronization of its generator with the AE system.
 - a. All required fault-detection relays shall coordinate with AE's devices, as necessary.
 - b. All interconnection relays shall be set to provide overlapping or coordinated protection to prevent extensive damage should an interrupting device fail to clear when required. The line-protection schemes shall be able to distinguish between generation, inrush, and fault current.
 - c. Where the existing relay schemes have to be reset, replaced, or augmented with additional relays to coordinate with the customer's new facility, all work shall be done at the customer's expense.
 - d. The customer must place the AE-required relays at a location where a fault on any phase of AE's interconnected line(s) can be detected.
 - e. If AE requires transfer-trip protection, the customer shall provide and pay for all the required communication circuits and equipment based on the protection studies.
 - f. The customer should contact Austin Energy to determine the phase rotation at their proposed site.
9. Dedicated Service. AE will determine the need and feasibility for dedicated service on a case-by-case assessment of each customer-owned power production facility. The customer is responsible for all connection charges above standard service.
 - a. Dedicated Transformer: AE may require a dedicated transformer; the customer shall be connected to the AE electric utility system through a dedicated power transformer provided at the sole expense of the customer.
 - b. Dedicated Feeder: Proposed Distributed Generation facilities may not represent greater than 25% of the existing feeder load or 25% of the maximum available fault available on the circuit without written approval from AE.
 - c. Solar PV DG facilities of 4 MW or larger will either require a dedicated feeder, or have the facility load split between multiple feeders to minimize/reduce voltage fluctuations that would affect other customers.
10. Relay Settings (if applicable). The settings for all distribution interconnections shall be approved by System Engineering in conjunction with IEEE 1547 and AE Transmission and Substation Engineering and Construction as necessary.

11. Communication.

For facilities greater than two (2) megawatts (MW), AE may require that a communication channel be provided by the customer to provide communication between AE and the customer's facility. The channel will be a mutually agreed upon medium and shall comply with the requirements of IEEE 1547.3.

12. Additional Requirements for Three-Phase Generators.

- a. All generating units must comply with all of the applicable standards of ANSI and IEEE.
- b. Synchronous machines
 - i. The distributed generation facility's circuit breakers shall be three-phase devices with electronic control.
 - ii. The Customer is solely responsible for proper synchronization of its generator with the AE system.
 - iii. The generator's excitation system shall conform to the field voltage versus time criteria specified in the most recent version of ANSI Standard C50.13.
 - iv. For generating systems greater than two (2) megawatts (MW) the customer shall maintain the AVR of each generating unit in service and operable at all times. AE shall be notified if the AVR is removed from service for maintenance or repair.
- c. Induction machines
 - i. The induction machines used for generation may be connected and brought up to synchronous speed (as an induction motor) if it can be demonstrated that the initial voltage drop at the point of interconnection is within the flicker limits specified in this document.
- d. Inverters
 - i. Line-commutated inverters do not require synchronizing equipment. Loss of AE power will de-energize inverter.
 - ii. Self-commutated inverters require synchronizing equipment. Any installation of this type must be approved by AE and is NOT allowed on any installation on the AE Network. Inverters capable of islanding while connected in parallel to the AE system must contain appropriate circuit interruption relays and breakers to prevent possible backfeed into the AE distribution system and must be approved by AE System Engineering.

13. Additional requirements for DG systems on the AE Secondary Network

- a. The area served by the AE Secondary Network is shown in section 1.12 of the AE Design Criteria Manual.
<http://www.austinenergy.com/About%20Us/Company%20Profile/AEDesignCriteria.pdf>
- b. The AE feeders have network protectors to prevent any power from exporting to the grid. Actuation is not desired since this can result in a power outage to the customer.

- c. In accordance with IEEE 1547.6, Austin Energy employs a de minimus scheme that limits generation below a usage threshold that would naturally prevent any backfeed into the system in order to prevent actuation of the network protectors. This requires installation of a minimum import relay (MIR) which can be interfaced to the inverter(s).
 - d. The inverter may establish itself when the incoming power from Austin Energy exceeds a predetermined percentage of the connected distributed generation. If incoming power drops below this threshold; the inverter will turn itself off and remain off for a minimum of 5 minutes. After this time delay has expired, the inverter may reconnect itself when the customer load again exceeds this percentage of the connected distributed generation.
 - e. Austin Energy will determine the percentage of generation allowed to prevent backfeed into the Network.
 - f. Distributed Generation on the AE network is not allowed to be self commutating for safety reasons.
14. Additional Requirements for Electric Energy Storage: Detailed procedures have not been developed at this time. Any installation of this type must be approved by AE System Engineering and Distribution Planning.
- a. Electric Energy storage systems are not allowed to be connected in parallel to the AE Secondary Network.
15. Other Devices. The foregoing provides a statement of the minimum requirements for parallel operation on the AE system. In addition, AE will have the right to specify certain protective devices including relays and circuit breakers that the customer must install at the customer's expense to operate in parallel with AE's system to protect the safety of its employees and equipment, maintain the reliability of the system or improve the accuracy of its metering equipment.

E. TECHNICAL EXCEPTIONS

1. AE will review and consider exceptions that customers may have to the "Requirements for Parallel Systems" provided, however, that legal requirements such as compliance with fire safety, electrical or construction codes may not be waived unless such law, code, or ordinance provides for waiver or approval of alternate requirements and then only under the conditions set out therein for the grant of such waiver or written approval of alternate requirements.
2. Customers desiring to present exceptions for consideration should submit in writing a completed description of the nature of each such exception to AE.

3. Customers submitting exceptions should also include recommendations for an alternative approach to this particular requirement.

F. DEFINITIONS

1. AE System: The Electric Utility System of Austin Energy (AE). A detailed map of the service area is available on the Austin Energy Storm Center Website: <https://my.austinenergy.com/outages/>
2. Customer: Refers to both co-generators and small power producers within the AE service area who use conventional fossil fuels or alternative sources such as solar, wind or biomass to produce power.
3. IEEE : Institute of Electrical and Electronics Engineers
4. Interconnection: The physical means by which electric energy is received from a generating source. The principal elements of an electric interconnection include transmission and distribution circuits, transformers and switching devices such as circuit breakers, fuses and isolating disconnect switches. Supplemental elements may include sensing devices and protective relay equipment.
5. Interconnection Point: The point at which energy first enters or leaves the line or apparatus owned by the customer and leaves or enters the line or apparatus owned by AE and is the point of common coupling as defined in IEEE 1547. Typically, this is defined as the load side of the revenue meter. (see NEC article 705.2)
6. Supplementary Electric Service: Electric power required on a regular basis to serve a portion of the customer's load in addition to that served by the customer's power source.
7. Maintenance Electric Service: Electrical power which is required to serve the customer's load during specific prearranged periods of scheduled outage of the customer's power source for maintenance or repair.
8. Isolated System: A system in which there is no interconnection of the customer's power source or load served by the customer's power source to an electrical circuit common with the AE electric utility system. Customers dedicating their power production equipment to a particular load without standby electric service from AE would be considered as having a totally isolated system.
9. Separate System: A system in which there is no intended interconnection of the customer's electrical generation system in parallel with the AE electric utility system but whose load receives standby service from AE. Customers dedicating their power production equipment to a particular load and who receive standby electric service for the load from AE must be

capable of transferring the load between the two electrical systems in an open transition in order to be considered as having a separate system; that is, the customer's power production equipment is not connected to the AE electric utility system directly or indirectly through the load. Typical emergency backup generation systems with an automatic transfer switch fall into this category.

10. Parallel System: A system in which the customer's electrical generation system can be connected to an electrical circuit common with the AE electric utility system. Customers who receive supplementary electric service from AE will be considered as having a parallel system. This system allows for the flow of power from AE to the customer and from the customer to AE. Typical distributed generation falls into this category.
11. UPS: An Uninterruptible Power Supply (UPS) system that is not normally capable of backfeed into the AE system other than brief transition periods will be classified as a Separate system. If the UPS system is capable of backfeeding into the AE system for periods exceeding 30 seconds, it will be classified as a Parallel system.
12. Backfeed: A situation whereby the normal power flow is reversed and current flows from the customer system into the AE distribution system.
13. Microgrid: A microgrid is a local energy network offering integration of DG with local electric loads, which can operate in parallel with the AE System or in an intentional island mode. This is a new type of system being developed and includes the use of DG paired with smart load shed/load management techniques to enable it to run in an islanded configuration. Although IEEE standard 1547.4 is available for review, AE procedures to handle this type of system have not been developed.
14. ESPA: Electric Service Planning Application form which is required to be filled out for any change in the service connection to the Austin Energy such as connecting a Distributed Generation system in parallel.
<http://www.austinenergy.com/About%20Us/Company%20Profile/AEDesignCriteria.htm>
15. Dedicated Service: A feeder or transformer, or both, in the AE Distribution system that only serves a single customer.
16. Network: The network refers to an area of the AE Distribution system in downtown Austin where multiple feeders are "networked" together. Areas of downtown Austin are on the network and due to safety and power quality concerns, additional protection is required so that **no** distributed generation facility will be allowed to export power to the AE grid. These requirements are documented in IEEE Standard 1547.6 and an analysis of the issues was documented by the National Renewable Energy Labs at:
<http://www.nrel.gov/docs/fv09osti/45061.pdf>

17. Electric Energy Storage: Although IEEE standard 1547.4 is available for review, detailed AE procedures to handle energy storage systems in parallel with the AE distribution system have not been developed. Electric Energy storage systems connected in parallel to the AE distribution system are considered to be distributed generation assets.

H. Certification Codes and Standards

(Refer to the most recent version of the following documents:)

City of Austin Electrical and Solar Energy Codes--

http://www.ci.austin.tx.us/development/onestop/codes_tech_info.htm

Austin Energy Design Criteria manual--

<http://www.austinenergy.com/About%20Us/Company%20Profile/AEDesignCriteria.pdf>

IEEE1547 Standard for Interconnecting Distributed Resources with Electric Power Systems (including IEEE 1547.1, 1547.2, 1547.3, 1547.4, and 1547.6)

UL 1741 Inverters, Converters, and Controllers for Use with Distributed Energy Resources

NESC, National Electrical Safety Code

NFPA 70, National Electrical Code

IEEE STD C37.90.1, IEEE Standard Surge Withstand Capability (SWC) Tests for Protective Relays and Relay Systems

IEEE STD C37.90.2, IEEE Standard Withstand Capability of Relay Systems to Radiated Electromagnetic Interference from Transceivers

IEEE STD C37.108, IEEE Guide for the Protection of Network Transformers

IEEE STD C57.12.44, IEEE Standard Requirements for Secondary Network Protectors

IEEE STD C62.41.2, IEEE Recommended Practice on Characterization of Surges in Low Voltage (1000V and Less) AC Power Circuits

IEEE STD C62.45, IEEE Recommended Practice on Surge Testing for Equipment Connected to Low-Voltage (1000V and Less) AC Power Circuits

ANSI C84.1, Electric Power Systems and Equipment – Voltage Ratings (60 Hertz)

IEEE STD 100, IEEE Standard Dictionary of Electrical and Electronic Terms

IEEE STD 519, IEEE Recommended Practices and Requirements for Harmonic Control in Electrical Power Systems

NEMA MG 1, Motors and Generators

California Energy Commission(CEC)Solar Energy Resource <http://www.gosolarcalifornia.org/>

Appendix A—Interconnection Package and Forms

Distributed Generation Application Approval Process – Customer

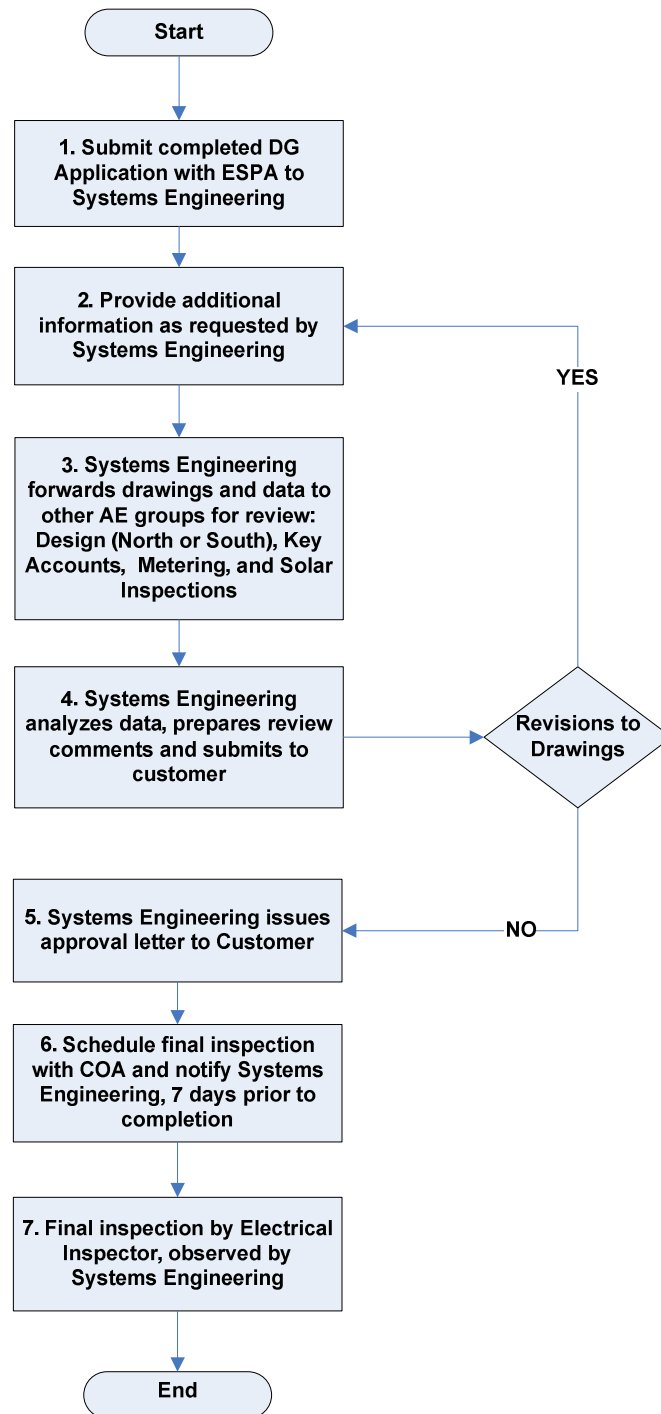

Application Package Checklist

- 1) Copy enclosed of completed ESPA Application

- 2) Copy enclosed of completed Distributed Generation Application
 - a. Application form
 - b. Customer information
 - c. DG application--either PV or rotating machine sheets
 - d. Interconnecting facilities information

- 3) Copy enclosed of site electrical one-line diagram and schematic drawings showing the configuration of all Distributed Generation equipment, current and potential circuits, and protection and control schemes, signed and stamped by a professional engineer licensed in the state of Texas.

- 4) Copy enclosed of any site documentation that indicates the precise physical location of the proposed distributed generation facility (e.g., USGS topographic map or other diagram or documentation).

- 5) Copy enclosed of proposed location of Disconnect Switch(es) in relation to meter, generator, and main service meter.

- 6) Copy enclosed of any site documentation that describes and details the operation of the protection and control schemes, as well as proposed directory/plaque location.

- 7) Copy enclosed of schematic drawings for all protection and control circuits, relay current circuits, relay potential circuits, and alarm/monitoring circuits (if applicable).

- 8) Enclosed initial payment per fee schedule(if applicable). (**refer to Section C.4**)

- 9) Upon completion of construction, schedule AE inspection at least 7 business days prior to energizing DG system.

Applicant Signature

I hereby certify that, to the best of my knowledge, all of the information provided in this Interconnection Request is true and correct.

Interconnection Customer: _____

Date: _____



Austin Energy Distributed Generation Application

(For facilities from 50 kW to <10 MW)

Designated Contact Person: _____

Address: _____

Telephone Number: _____

Fax: _____

E-Mail Address: _____

Requested In-Service Date: _____

An Interconnection Request is considered complete when it provides all applicable and correct information as required on the following pages.

Preamble and Instructions

An Interconnection Customer who requests an Austin Energy jurisdictional interconnection must submit this Interconnection Request by hand delivery, mail, e-mail, or fax.

Processing Fee or Deposit:

The Interconnection Customer shall submit to Austin Energy a deposit towards the cost of the feasibility study as detailed on the Austin Energy Fee Schedule.

<http://www.austinenergy.com/About%20Us/Rates/feeSchedule.pdf>

Interconnection Customer Information

Legal Name of the Interconnection Customer (or, if an individual, individual's name)

Name: _____

Contact Person: _____

Mailing Address: _____

City: _____ State: _____ Zip: _____

Facility Location (if different from above): _____

Telephone (Day): _____ Telephone (Evening): _____

Fax: _____ E-Mail Address: _____

Application is for:

_____ New Small Generating Facility _____ Capacity addition to Existing Facility

A) If capacity addition to existing facility, please describe: _____

B) Provide existing Account Number _____

Will the Small Generating Facility use Net Metering? Yes ___ No ___

Is customer site in the AE Downtown Network? Yes _____ No _____

Interconnection Customer or Customer-Site Load: _____ kW (if none, so state)

Maximum Physical Export Capability Requested: _____ kW

Distributed Generation Facility Information

(Data apply only to the Generating Facility, not the Interconnection Facilities.)

Technology Type: ___ Renewable ___ Non-renewable

Fuel Type: ___ Solar ___ Wind ___ Diesel ___ Natural Gas ___ Fuel Oil
___ Other (state type) _____

Type of Generator: ___ Synchronous ___ Induction ___ Inverter

Distributed Generation Application for Solar PV

Generator (or solar collector)

Manufacturer, Model Name & Number: _____ Version Number: _____

Nameplate Output Power Rating in kW: (Summer) _____ (Winter) _____

Nameplate Output Power Rating in kVA: (Summer) _____ (Winter) _____

Inverter Manufacturer, Model Name & Number (if used): _____

Is the inverter on the CEC list of approved equipment? ___ Yes ___ No

List components of the Small Generating Facility equipment package that are currently certified:

Equipment Type	Certifying Entity
1. _____	_____
2. _____	_____
3. _____	_____
4. _____	_____
5. _____	_____

Is the generation equipment compatible with the certified protective relay package? ___ Yes ___ No

List of adjustable set points for the protective equipment or software: _____

Distribution Facility Characteristic Data for inverter-based machines

Max design fault contribution current: _____ Instantaneous ___ or RMS? ___

Harmonics Characteristics: _____

Start-up requirements: _____

Note: A completed ESPA data sheet must be supplied with the Interconnection Request.

For installations <1.0MW, City permits should be obtained using the Quick-turn process.

Interconnection Facilities Information

Part A Transformer

Will a transformer be used between the generator and the point of common coupling? ___ Yes ___ No

Will the transformer be provided by the ___ Interconnection Customer or ___ AE?

If transformer is provided by AE, the rest of part A (below) is left blank

Transformer Data (for Customer-Owned Transformer only):

Size: _____ kVA Transformer Impedance: _____ % on _____ kVA Base

Transformer Primary: ___ Volts ___ Delta ___ Wye ___ Wye Grounded

Transformer Secondary: ___ Volts ___ Delta ___ Wye ___ Wye Grounded

Transformer Tertiary: ___ Volts ___ Delta ___ Wye ___ Wye Grounded

Transformer Fuse Data (if applicable):

Manufacturer: _____ Type: _____ Size: _____ Speed: _____

Interconnecting Circuit Breaker (if applicable):

Manufacturer: _____ Type: _____

Load Rating (Amps): _____ Interrupting Rating (Amps): _____ Trip Speed (Cycles): _____

Interconnection Protective Relays (If Applicable):

List of Functions and Adjustable Setpoints for the protective equipment or software:

Setpoint Function	Minimum	Maximum
1.	___	___
2.	___	___
3.	___	___

Part B - Reconnection Time

Programmed Time Delay for Reconnection after Interruption:

___ 300 Seconds(default) ___ Other (specify) _____

Distributed Generation Application for Rotating Machines
(not required for Solar PV systems)

RPM Frequency: _____

(*) Neutral Grounding Resistor (If Applicable): _____

Synchronous Generators:

Direct Axis Synchronous Reactance, X_d : _____ P.U.

Direct Axis Transient Reactance, X'_d : _____ P.U.

Direct Axis Subtransient Reactance, X''_d : _____ P.U.

Negative Sequence Reactance, X_2 : _____ P.U.

Zero Sequence Reactance, X_0 : _____ P.U.

KVA Base: _____

Field Volts: _____

Field Amperes: _____

Induction Generators:

Motoring Power (kW): _____

Locked Rotor current _____

$I_2^2 t$ or K (Heating Time Constant): _____

Rotor Resistance, R_r : _____ P.U.

Stator Resistance, R_s : _____ P.U.

Stator Reactance, X_s : _____ P.U.

Rotor Reactance, X_r : _____ P.U.

Magnetizing Reactance, X_m : _____ P.U.

Short Circuit Reactance, X_d'' : _____ P.U.

Exciting Current: _____

Temperature Rise: _____

Frame Size: _____

Design Letter: _____

Reactive Power Required In KVars (No Load): _____

Reactive Power Required In KVars (Full Load): _____

Total Rotating Inertia, H: _____ Per Unit on kVA Base

Excitation and Governor System Data for Synchronous Generators Only

Individual Generator Power Factor

Rated Power Factor: Leading: _____ Lagging: _____

If Discrete Components:

(Enclose Copy of any Proposed Time-Overcurrent Coordination Curves)

Manufacturer: _____ Type: _____ Style/Catalog No.: _____ Proposed Setting: _____
Manufacturer: _____ Type: _____ Style/Catalog No.: _____ Proposed Setting: _____
Manufacturer: _____ Type: _____ Style/Catalog No.: _____ Proposed Setting: _____
Manufacturer: _____ Type: _____ Style/Catalog No.: _____ Proposed Setting: _____
Manufacturer: _____ Type: _____ Style/Catalog No.: _____ Proposed Setting: _____

Current Transformer Data (If Applicable):

(Enclose Copy of Manufacturer's Excitation and Ratio Correction Curves)

Manufacturer: _____
Type: _____ Accuracy Class: ___ Proposed Ratio Connection: _____

Manufacturer: _____
Type: _____ Accuracy Class: ___ Proposed Ratio Connection: _____

Potential Transformer Data (If Applicable):

Manufacturer: _____
Type: _____ Accuracy Class: ___ Proposed Ratio Connection: _____

Manufacturer: _____
Type: _____ Accuracy Class: ___ Proposed Ratio Connection: _____